

Engineering Manufacturing Knowledge Organiser - Contents

Unit R014 – Principles of engineering manufacture

Learning Outcome/Topic Area 1: Manufacturing processes – pages 3-15

Learning Outcome/Topic Area 2: Engineering materials- pages 16 -24

Learning Outcome/Topic Area 3: Manufacturing requirements – pages 25-37

Learning Outcome/Topic Area 4: Developments in engineering manufacture –pages 38-39

Unit R015: Manufacturing a one-off product

Learning Outcome/Topic Area 1: Planning the production of a one-off product – pages 41-46

Learning Outcome/Topic Area 2: Measuring and marking out – pages 47-55

Learning Outcome/Topic Area 3: Safely use processes, tools and equipment to make a product – pages 56-61

Unit R016: Manufacturing in quantity

Learning Outcome/Topic Area 1: Preparing for manufacture – pages 63-64

Learning Outcome/Topic Area 2: Develop programmes to operate CNC equipment- pages- 65- 66

Learning Outcome/Topic Area 3: Safely use processes and equipment to make products in quantity- page- 67

Additional Useful Information pages – 68-73

Engineering Manufacturing Knowledge Organiser

Unit R014 – Principles of engineering manufacture

Learning Outcome/Topic

Area 1: Manufacturing processes

Learning Outcome/Topic Area 2:

Engineering materials

Learning Outcome/Topic Area 3:

Manufacturing requirements

Learning Outcome/Topic Area 4:

Developments in engineering
manufacture

Unit R014 – Principles of engineering manufacture

Learning Outcome 1: Manufacturing processes

1.1 Types of manufacturing processes

1.1.1 The type of manufacturing processes

Wasting - **The process of taking something away from a material** is called wasting. It is given this name because the material which has been removed such as the shaving and dust are generally thrown away as waste. Shaping by wasting can be done by using machinery or hand tools and on various different materials.

Shaping - Shaping is **used to change the size and shape of a workpiece**. Like planing, it will remove material from the workpiece. The cutting tool will press against the stationary workpiece while removing material from it. Unlike planing, however, it doesn't create a sculpted surface.

Forming - Forming is **a mechanical process used in manufacturing industries wherein materials (mostly metals) undergo plastic deformations and acquire required shapes and sizes by application of suitable stresses such as compression, shear and tension**.

Additive processes - Additive manufacturing is process by which digital 3D design data is used to build up a component by depositing material. Examples of this are:

Selective Laser Sintering (SLS), Stereolithography (SLA), Direct Metal Laser Sintering (DMLS), Fused Deposition Modelling (FDM), 3D printing, Electron beam melting

Joining - Joining processes include **welding, brazing, soldering, mechanical fastening, and adhesive bonding** (Fig. 1.2). Mechanical fastening can be used to provide either temporary or permanent joints, while adhesive bonding, welding, brazing, and soldering processes are mainly used to provide permanent joints

Finishing - **Finishing**

- Introduction to finishing processes. Finishing processes aim to alter the surface of a manufactured part in order to achieve a particular characteristic. ...
- Spraying. ...
- Powder coating. ...
- Dip coating. ...
- Electroplating. ...
- Plating. ...
- Anodizing. ...
- Electroless plating.

1.1.2 How each process type changes the form of materials to create a product- recognising how different processes alter the shape of a material and which processes are the most suitable.

Unit R014 – Principles of engineering manufacture

Learning Outcome 1: Manufacturing processes

1.2 Details of different manufacturing processes

1.2.1 Wasting processes

Sawing - Sawing is a process wherein **a narrow slit is cut into the workpiece by a tool consisting of a series of narrowly spaced teeth, called a saw blade**. Sawing is used to separate work parts into two or more pieces, or to cut off an unwanted section of a part

Shearing - Shearing is **the process of cutting sheet metal to size out of a larger roll or flat stock**. As the material moves through the shear machine, cutting blades come together in order to fracture the material into separate, smaller pieces. This process creates quality clean cuts that can be repeated quickly.

Drilling - Drilling is **the process of cutting holes in a solid material using a rotating cutting tool**. The indentation is a starting point for the drilling of the hole. Drilling is a cutting process in which a drill bit is used to cut or enlarge a hole in a solid material.

Filing - Filing is **a material removal process in manufacturing**. Similar, depending on use, to both sawing and grinding in effect, it is functionally versatile, but used mostly for finishing operations, namely in deburring operations. Filing operations can be used on a wide range of materials as a finishing operation.

Threading - Thread cutting is **a process for generating a thread**. It's used for the production of threads on the outer surface of a cylinder or on the inner surface of a bore. Tools used for thread cutting are the thread cutting die, the the screw tap or for serial production a process called cold or hot forming.

Routing - The process of hollowing out an area of material. The router is **a power tool with a flat base and a rotating blade extending past the base**. The spindle may be driven by an electric motor or by a pneumatic motor. It routs (hollows out) an area in hard material, such as wood or plastic.

Laser cutting - Laser cutting is **a slitting process with which it is possible to cut metallic and non-metallic raw materials of different material thicknesses**. This is based around a laser beam which is guided, focused, and bundled. When it hits the workpiece, the material heats up to the extent that it melts or vaporises

Unit R014 – Principles of engineering manufacture

Learning Outcome 1: Manufacturing processes

1.2 Details of different manufacturing processes

1.2.1 Wasting processes

Turning - Turning is a form of machining, a material removal process, which is used to create rotational parts by cutting away unwanted material. The turning process requires a turning machine or lathe, workpiece, fixture, and cutting tool.

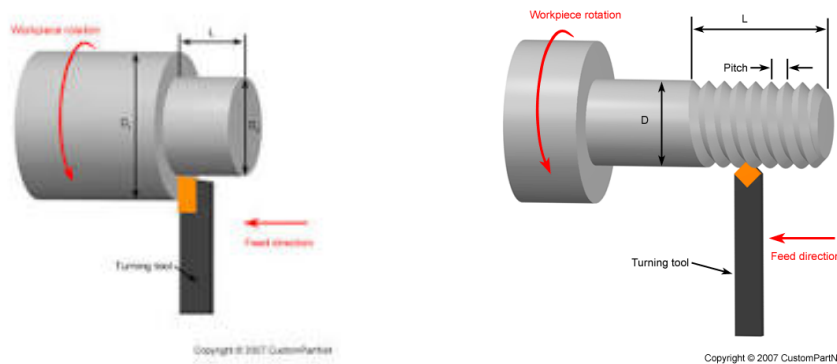

Milling - Milling is the process of machining using rotary cutters to remove material^[1] by advancing a cutter into a workpiece. This may be done varying direction^[2] on one or several axes, cutter head speed, and pressure.

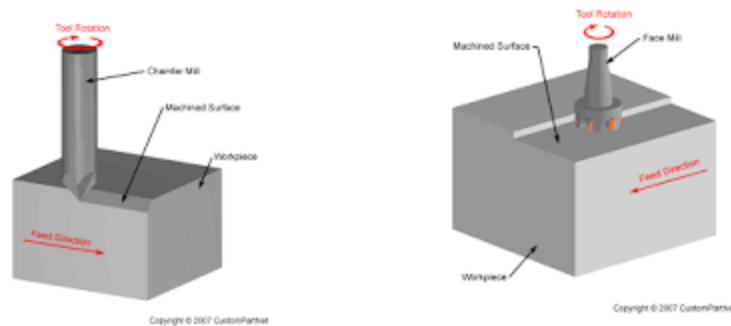

Learning Outcome 1: Manufacturing processes

1.2 Details of different manufacturing processes

1.2.2 Shaping processes

Sand casting - **What is a sand casting process?**

Sand casting is a **manufacturing process in which liquid metal is poured into a sand mold, which contains a hollow cavity of the desired shape, and then allowed to solidify.**

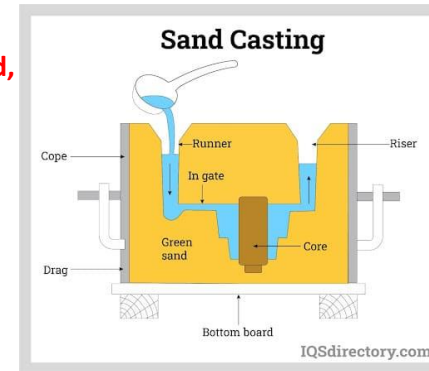

Die casting - **Die casting is a metal casting process that involves feeding molten nonferrous alloys into dies under high pressure and at high speed to rapidly create molded products.**

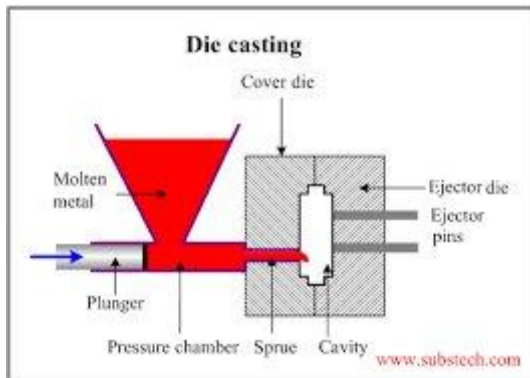

Learning Outcome 1: Manufacturing processes

1.2 Details of different manufacturing processes

1.2.2 Shaping processes

Injection moulding - **What is Injection Moulding?** Plastic injection moulding is **the process of melting plastic pellets (thermosetting/ thermoplastic polymers) that once malleable enough, are injected at pressure into a mould cavity, which fills and solidifies to produce the final product.**

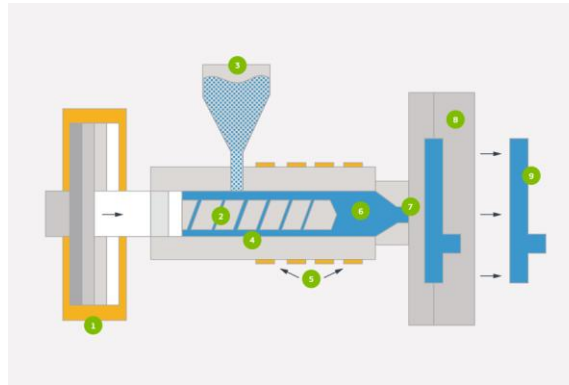

Powder metallurgy for ceramic product

What is powder metallurgy in ceramics?

Powder Metallurgy and Metal Ceramics covers topics of the theory, manufacturing technology, and properties of powder; technology of forming processes; the technology of sintering, heat treatment, and thermo-chemical treatment; properties of sintered materials; and testing methods.

Learning Outcome 1: Manufacturing processes

1.2 Details of different manufacturing processes

1.2.3 Forming processes

Forging - Metal forging is **the process in which metals are formed and shaped using compressive forces**. The forces are delivered using hammering, pressing, or rolling. There are a number of forging processes – cold forging, warm forging, and hot forging – which are classified by the temperature of the metal being worked with.

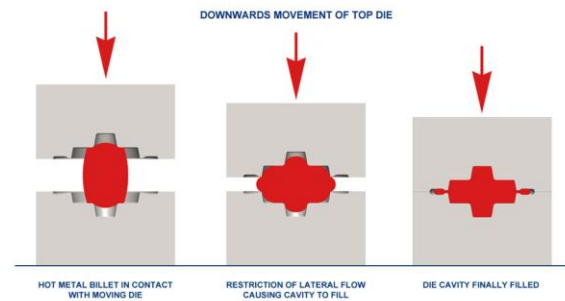

Press forming metal **What is a metal forming press? A metal forming press, also known as a stamping press, is a machine tool used to precisely shape and cut metal typically using upward and downward movements.** Metal, supplied in sheet, coil, or tube form, is pressed between two halves of a press tool

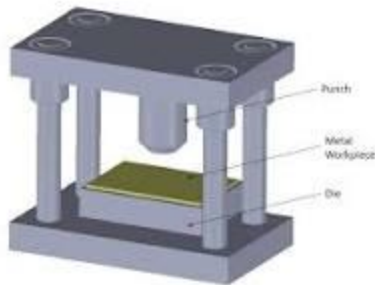

Learning Outcome 1: Manufacturing processes

1.2 Details of different manufacturing processes

1.2.3 Forming processes

Strip heating of polymers - This **heats the plastic along a line so that it becomes soft and flexible**. It can then be folded to almost any angle. Thermoplastics such as Acrylic (Perspex) are most suitable for this type of product as they can be shaped when heated

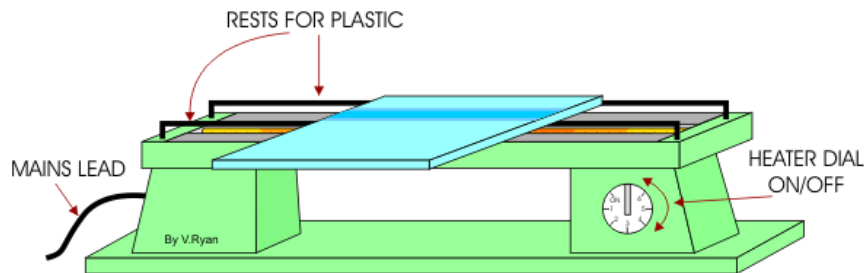

Vacuum forming - Vacuum forming is a simplified version of thermoforming, where a sheet of plastic which is called HIPS is heated to a forming temperature, stretched onto a single-surface mould, and forced against the mould by a vacuum.

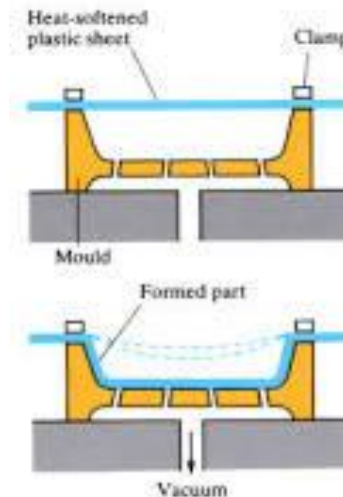

Learning Outcome 1: Manufacturing processes

1.2 Details of different manufacturing processes

1.2.3 Forming processes

Moulding of composite materials - *What is Moulding in composites?*

The term liquid composite moulding (LcM) summarises a variety of process technologies such as resin transfer moulding (RTM), reaction injection moulding (RIM) and vacuum-assisted resin injection (VARI) that use thermoset resins and continuous fabric reinforcements to produce fibre-reinforced composites.

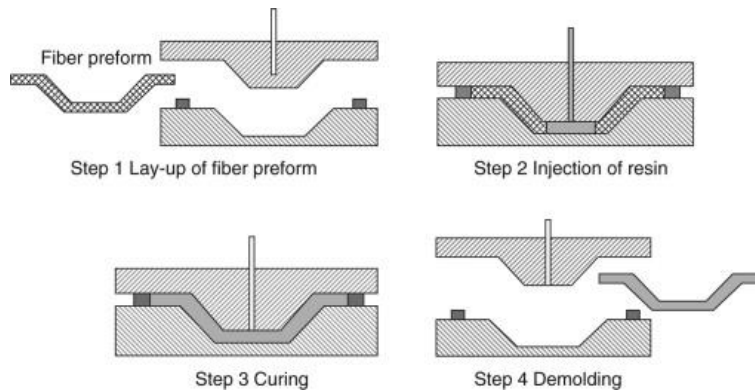

Learning Outcome 1: Manufacturing processes

1.2 Details of different manufacturing processes

1.2.4 Additive manufacturing

3D printing (fused deposition modelling) - 3D printing or additive manufacturing/fused deposition modelling is the construction of a three-dimensional object from a CAD model or a digital 3D model. It can be done in a variety of processes in which material is deposited, joined or solidified under computer control, with material being added together, typically layer by layer



Learning Outcome 1: Manufacturing processes

1.2 Details of different manufacturing processes

1.2.5 Joining processes

Brazing - Brazing is a metal-joining process in which two or more metal items are joined together by melting and flowing a filler metal into the joint, with the filler metal having a lower melting point than the adjoining metal. Brazing differs from welding in that it does not involve melting the work pieces.

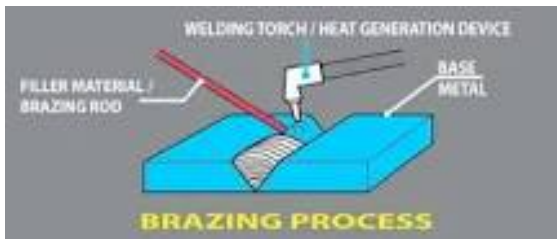

MIG/MAG welding - Metal Inert Gas (MIG) and Metal Active Gas (MAG) welding are gas metal arc welding (GMAW) processes that use heat created from a DC electric arc between a consumable metal electrode and a workpiece which melt together to create a weldpool that fuses to form a join.

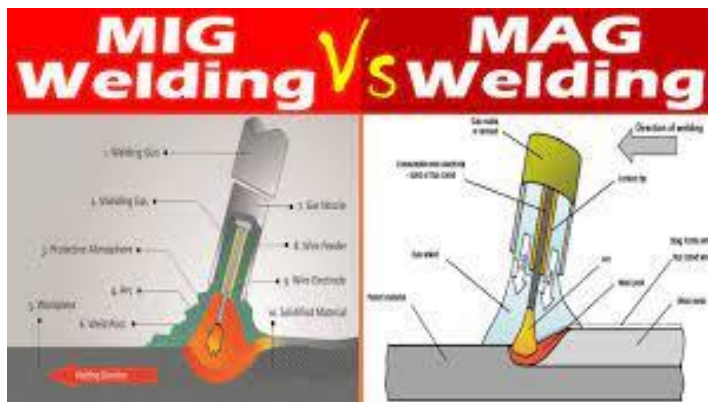

Learning Outcome 1: Manufacturing processes

1.2 Details of different manufacturing processes

1.2.5 Joining processes

Riveting - Hammered rivets - An example of a rivet is a metal piece for securing two pieces of metal together. noun. 1. 1. A metal bolt or pin having a head on one end, inserted through aligned holes in the pieces to be joined and then hammered on the plain end so as to form a second head. An example of a rivet is a metal piece for securing two pieces of metal together. noun. 1. 1. A metal bolt or pin having a head on one end, inserted through aligned holes in the pieces to be joined and then hammered on the plain end so as to form a second head.



- Pop rivets - A POP Rivet is a **blind fastener which can be inserted and set from one side of the work piece**. Depending on the application, they can be used as replacements for welds, adhesives, screws, nuts and bolts. A typical POP Rivet is made up of two key parts; the rivet body and the setting mandrel.

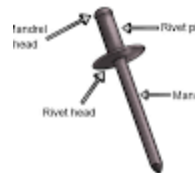
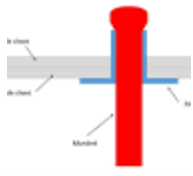

Learning Outcome 1: Manufacturing processes

1.2 Details of different manufacturing processes

1.2.5 Joining processes

Mechanical fastening - What are the 3 types of mechanical fasteners?

There are three main types of threaded fastener; **Bolts, Screws and Studs**. Bolts have a head on one end (this is usually a hex head) and are threaded on the other. They are generally used in conjunction with a nut (and sometimes a washer) to hold them in place.

- Nuts bolts -
- Self-tapping screws

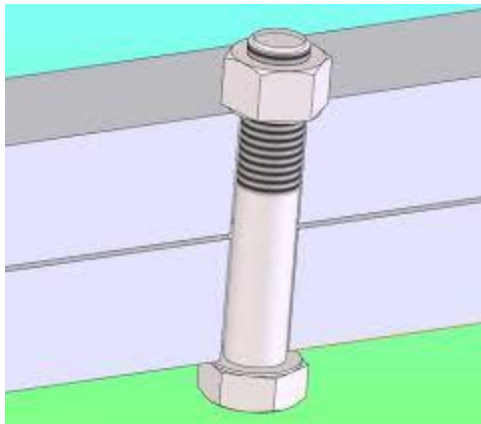

Fastener Categories			Nut Types		
 <p>Wood Screws Screws with tapered shank and tapered point for use in wood. Also known as: Antennascrews</p>	 <p>Machine Screws Threads with standard pitch and uniform longitudinal pitch. Also known as: Antennascrews</p>	 <p>Thread Colling Machine Screws Features coarse pitch and uniform longitudinal pitch. Also known as: Antennascrews</p>	 <p>Heavy Hex A hex nut with a standard hexagonal shape.</p>	 <p>Nylon Insert Lock A nut with a nylon insert to prevent backing off. Also known as: Nylon nuts</p>	 <p>Jam A nut with a tapered shape.</p>
 <p>Self Drilling SHS A self-drilling screw with a self-drilling point.</p>	 <p>Hex Bolts A bolt with a hexagonal head and a threaded shaft. Also known as: Hex bolts</p>	 <p>Carriage Bolts A bolt with a square head and a threaded shaft. Also known as: Carriage bolts</p>	 <p>Wing A nut with a winged head for easy tightening.</p>	 <p>Cap A nut with a rounded top and a hexagonal base.</p>	 <p>Acorn A nut with a rounded top and a hexagonal base. Also known as: Acorn nuts</p>
 <p>Tubular Screws Screws with a tubular shank and a self-drilling point. Also known as: Tubular screws</p>	 <p>Set Screws A screw with a flat end and a threaded shaft. Also known as: Set screws</p>	 <p>Eye Bolts A bolt with a hook-shaped head and a threaded shaft. Also known as: Eye bolts</p>	 <p>Tee A nut with a T-shaped head and a threaded shaft.</p>	 <p>Square A nut with a square head and a threaded shaft.</p>	 <p>Preloading Torque Lock A nut with a hexagonal head and a threaded shaft. Also known as: Preloading torque lock nuts</p>
			 <p>Coupling A nut with a cylindrical head and a threaded shaft. Also known as: Coupling nuts</p>	 <p>Shoulder A nut with a cylindrical head and a threaded shaft. Also known as: Shoulder nuts</p>	 <p>Castle A nut with a hexagonal head and a threaded shaft. Also known as: Castle nuts</p>



Learning Outcome 1: Manufacturing processes

1.2 Details of different manufacturing processes

1.2.6 Finishing processes

Painting

- Brush – **Brush painting is a process where a brush is used to apply paint to a surface**
- Spray- **Spray painting is a painting technique in which a device sprays coating material through the air onto a surface. The most common types employ compressed gas—usually air—to atomize and direct the paint particles.**

Powder coating - Powder coating is a type of coating that is applied as a free-flowing, dry powder. Unlike conventional liquid paint which is delivered via an evaporating solvent, powder coating is typically applied electrostatically and then cured under heat or with ultraviolet light.

Learning Outcome 2 : Engineering materials

Keywords		Properties of Engineering Materials
2.1 Mechanical properties of materials		
Hardness	➔	Ability to resist surface scratches
Ductility	➔	Ability to be stretched out into a wire using tensile force
Plasticity	➔	Ability to be shaped or moulded
Elasticity	➔	Ability to return to original shape after being stretched or compressed
Toughness	➔	Ability to withstand impact
Conductivity /Resistivity	➔	Ability to conduct or resist electricity or heat
Brittleness	➔	Ability to be easily damaged
Strength- Yield/tensile	➔	Tensile strength is the ability of a material to withstand a pulling (tensile) force
Compressive	➔	Compressive strength is the resistance of a material to breaking under compression
2.2 other properties/characteristics influencing manufacturing		
Malleability	➔	Ability to be shaped without breaking
Machinability	➔	Ability to be easily cut by machinery
Cost - material	➔	How expensive material is to purchase
Cost - manufacture	➔	How expensive a product is to make or manufacture
Sustainability	➔	The creation of manufactured products through economically-sound processes that minimize negative environmental impacts while conserving energy and natural resources

Learning Outcome 2 : Engineering materials

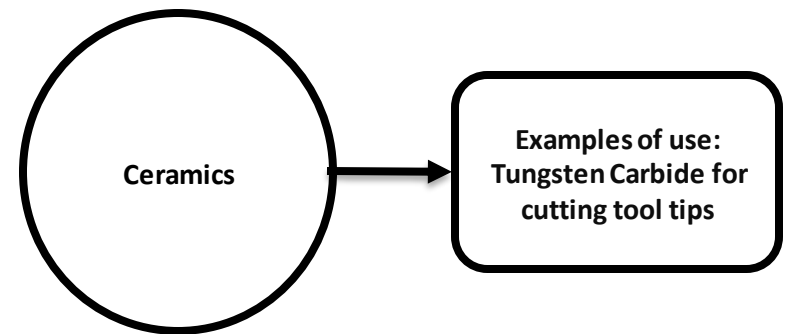
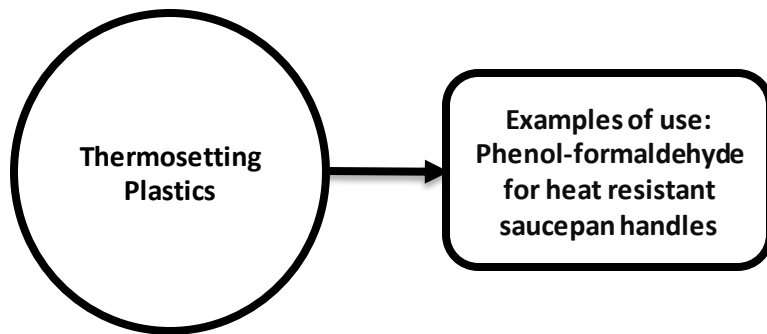
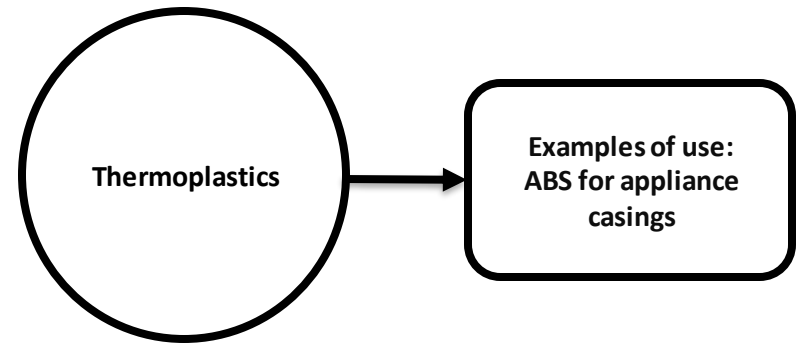
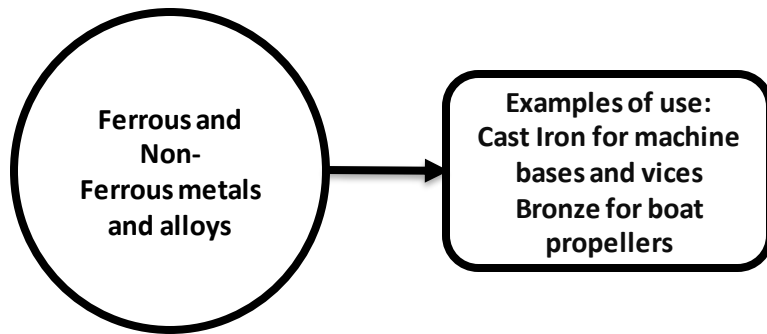

Learning Outcome 2: Engineering materials

Materials

Metals → materials that are made by processing an ore (an ore is usually an oxide of a metal in the form of a rock)

Ferrous metals - → contain iron are usually magnetic and rust.

Common examples; Cast Iron, Low carbon steel, High carbon steel, Stainless steel

Non-Ferrous metals - → do NOT contain iron, are not magnetic and tend to rust less.

Common examples; copper, brass, bronze, aluminium alloys, zinc, tin, lead, titanium.

Alloys - → metals that are commonly made up from two or more metals

Polymers - → are made up of a large number of similar chemical units that are bonded together. Polymers are usually made from crude oil.

Thermoplastics - → Become soft when heated and can be reheated and shaped many times. They can normally be recycled when melted down.

Common examples; Acrylonitrile-Butadiene-Styrene (ABS), Polyethylene, High impact polystyrene (HIPS) Polyvinyl chloride (PVC), Nylon, Polycarbonate, Polypropylene (PP)

Thermosetting plastics - → Can only be heated and shaped ONCE. They CANNOT be recycled.

Common examples; Polyester resin, Urea-formaldehyde, Epoxy resin, Phenol-formaldehyde.

Learning Outcome 2. 3 Types of engineering materials and how they are processed

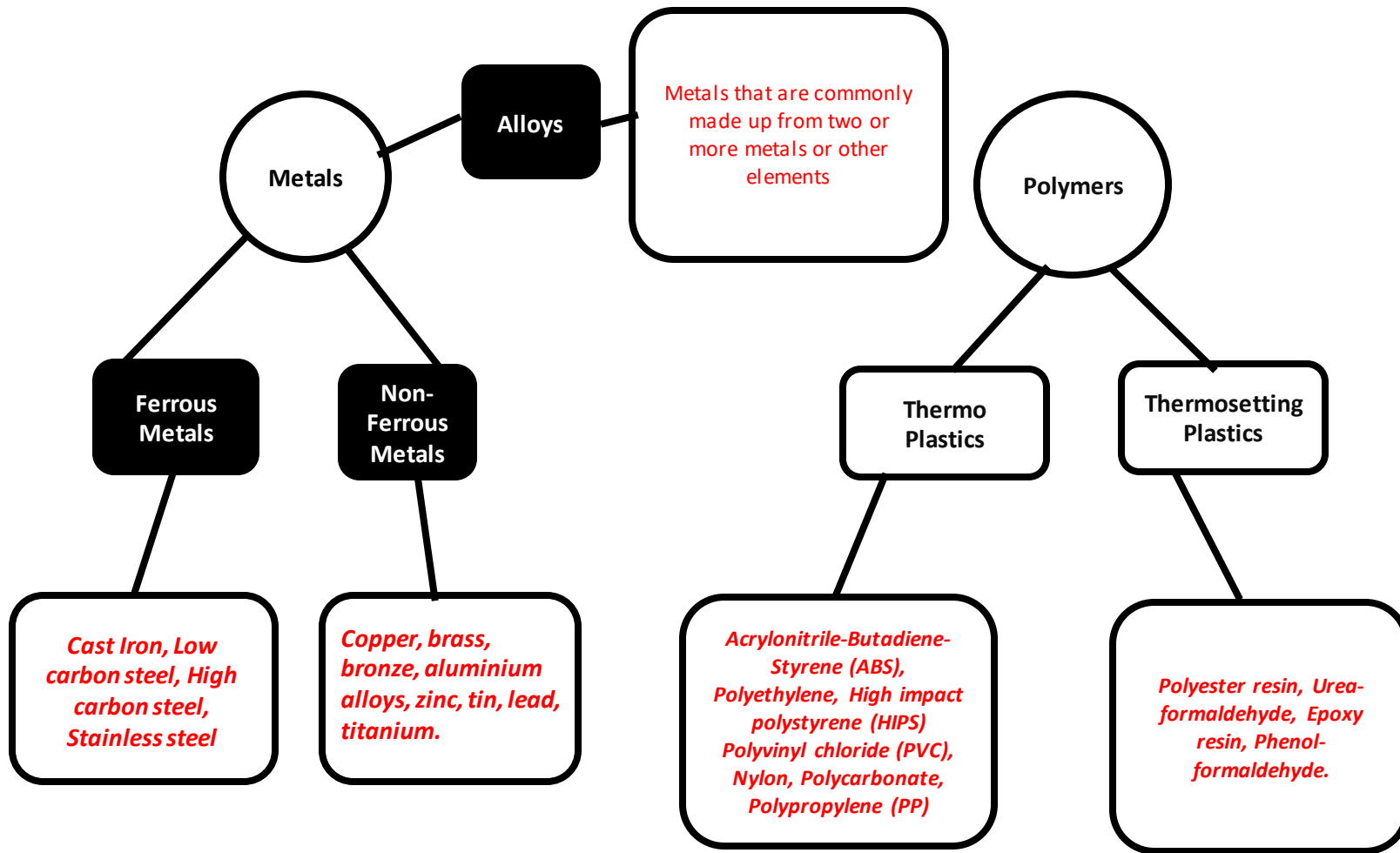

Learning Outcome 2 : Engineering materials

2.3 Types of engineering materials and how they are processed

2.3.1 Metals:

Difference between pure metal and alloys-**Pure metals consist of only one type of atom.** For example, chromium is on the periodic table of elements, meaning it's a pure metal. An alloy, by contrast, is a mixture of different atoms melded together.

Types of ferrous metal

- Cast iron
- Low carbon steel
- High carbon steel
- Stainless steel

Types of non-ferrous metal

- Aluminium and alloys
- Copper, brass and bronze

Learning Outcome 2 : Engineering materials

2.3 Types of engineering materials and how they are processed

2.3.2 Polymers:

Difference between thermoplastic and thermosetting polymers- **Thermosetting polymers and thermoplastic polymers are both polymers, but they behave differently when exposed to heat. Thermoplastics can melt under heat after curing while thermoset plastics retain their form and stay solid under heat once cured**

Types of thermoplastic polymer

- Acrylonitrile-Butadiene-Styrene (ABS)
- High Impact Polystyrene (HIPS)
- Polymethylmethacrylate (PPMA/Acrylic)
- Polycarbonate
- Polylactic acid(PLA)

Types of thermosetting polymer

- Urea formaldehyde
- Melamine formaldehyde
- Epoxy resin
- Polyester resin

Learning Outcome 2 : Engineering materials

2.3.3 Engineering ceramics

Ceramics – → typically an oxide, nitride or carbide of a metal. They are very hard, usually resistant to corrosion and are good insulators.

Common examples; tungsten carbide, silicate glass, silicon carbide, ceramic bearing material

2.3.4 Composite materials- → Materials that are made by combining different materials to make a new material with specific properties.

Common examples; Glass reinforced polymer (GRP/fibreglass), Carbon reinforced polymer (CRP), concrete.

2.3.5 Smart materials – → Materials that react to stimulus from their environment such as light or heat.

Common examples; shape memory alloys, (SMA) thermochromic materials/pigment, photochromic materials/pigment, shape memory plastics, Quantum tunnelling composite (QTC)

Learning Outcome 2: Engineering Materials

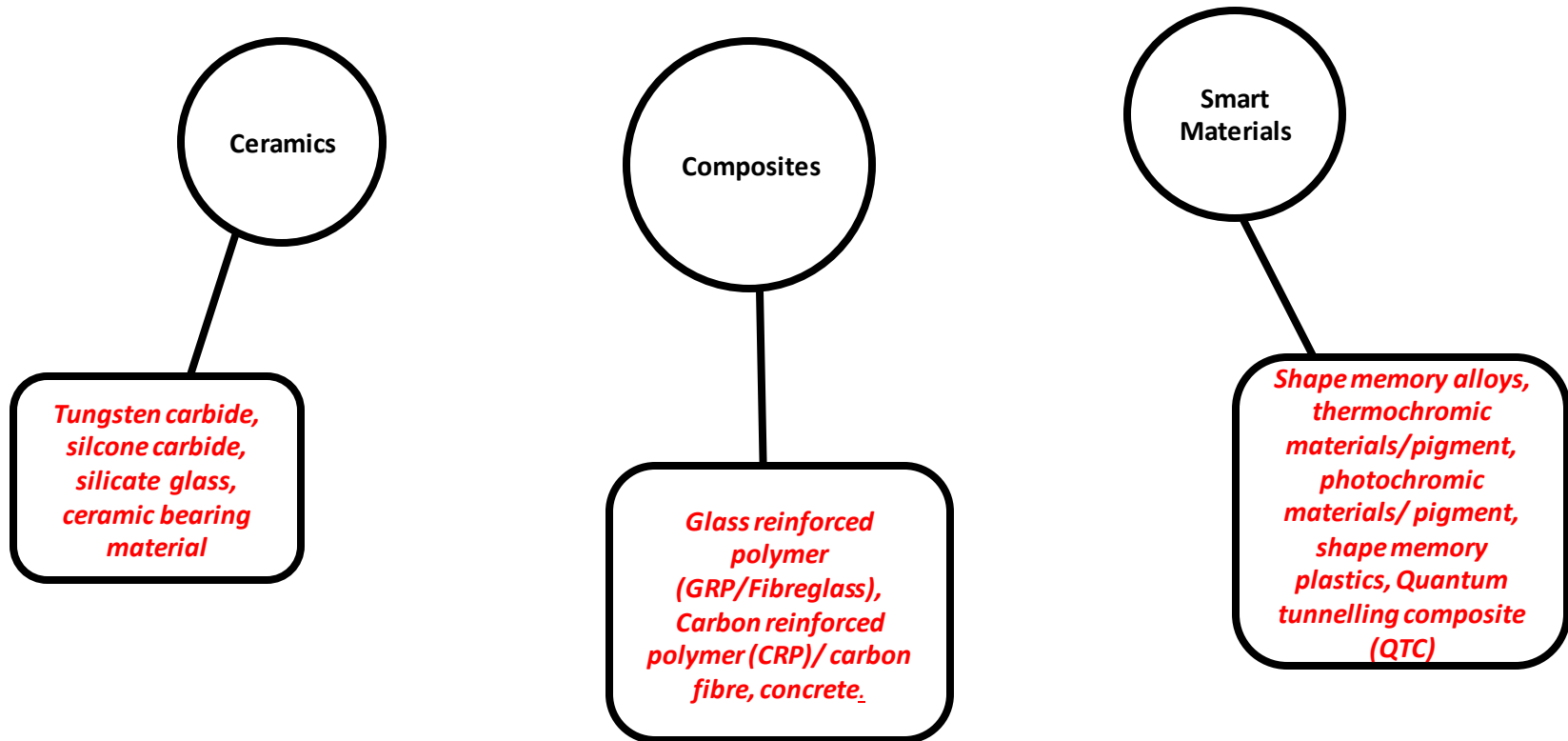

Learning Outcome 2: Engineering Materials

Characteristics of Engineering Materials

- Relative Cost-** → How expensive is the material to produce and source?
- Availability-** → Is it widely available and from a reliable source
- Ease of Use-** → Is it easy to use or does it need specialist equipment?
- Safety in Use-** → What safety precautions need to be taken?
- Forms of Supply-** → What stock form does the material come in such as sheet or bar?
- Sustainability-** → Is the material from a sustainable supply and can it be recycled or reused after use?

Uses of Specific Materials

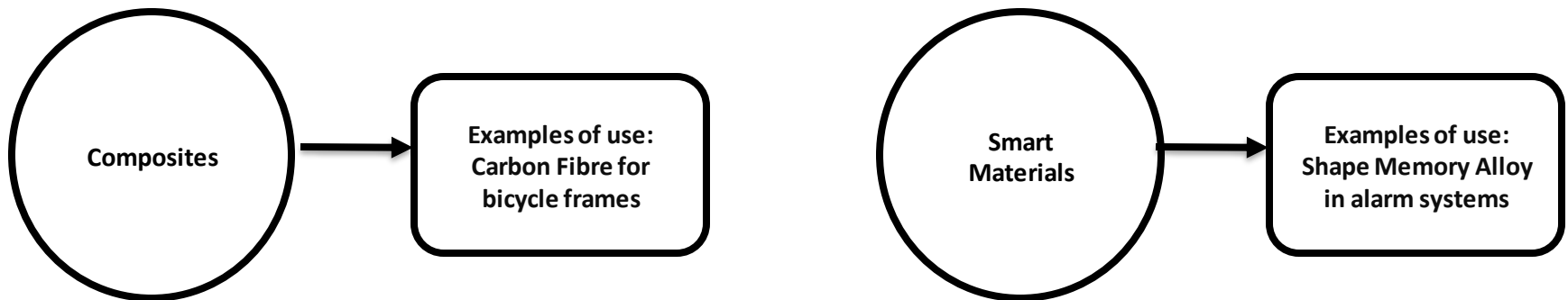

Learning Outcome 3 : Manufacturing requirements

3.1 Interpreting orthographic third angle projection drawings

Meaning of line types

- Outlines -
- Centreline
- Dimension

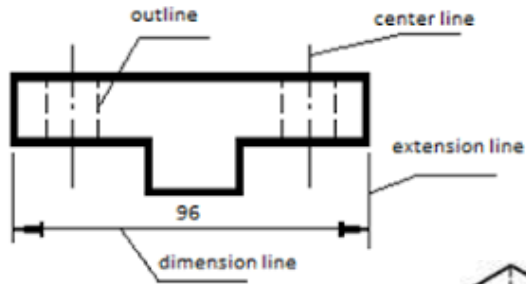

- Hidden detail -

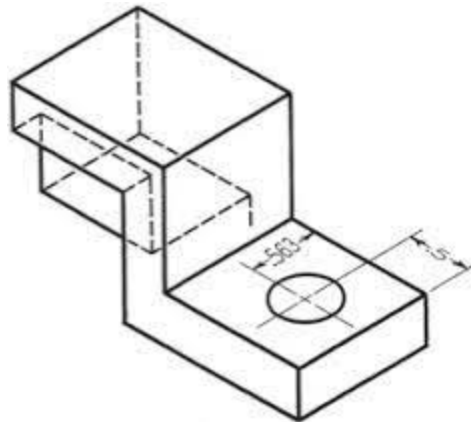

PROJECTION SYMBOLS

- Projection

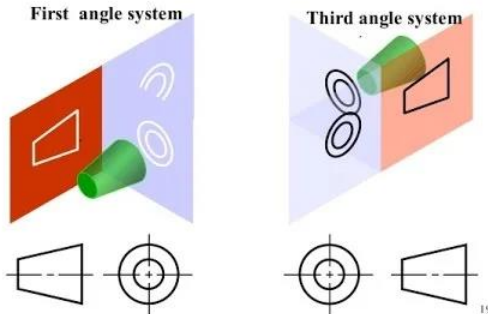

Learning Outcome 3 : Manufacturing requirements

3.1 Interpreting orthographic third angle projection drawings

Meaning of line types

- Leader line-Leaders are **more thin lines used to point to an area of a drawing requiring a note for explanation.** They are preferably drawn at a 45° angles

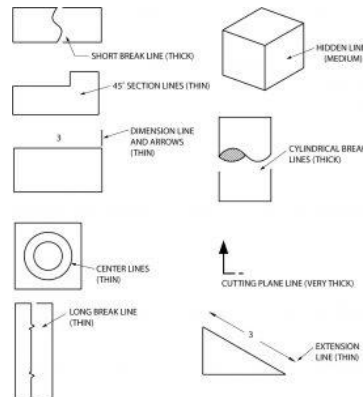

Standard conventions for dimensions

- Linear measurements - Linear measurement can be defined as **a measure of length.** The length. of a table, the length of a piece of pipe and the length of a football field are all examples of linear measurement. We might also refer to it as distance. Linear measurements represent a single dimension

- Radius - **the length of a line segment between the center and circumference of a circle or sphere.**

Radius (noun). a straight line from the center to the perimeter of a circle (or from the center to the surface of a sphere)

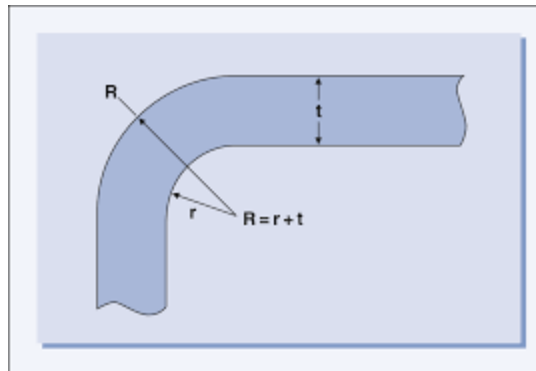

Learning Outcome 3 : Manufacturing requirements

3.1 Interpreting orthographic third angle projection drawings

Meaning of line types

- Diameter - Diameter is **the full length of the circle running from the edge, through the midpoint, all the way to the other side**. That is this whole length right here. The diameter of a circle is represented by the letter *d*. It is shown on engineering drawings by the symbol

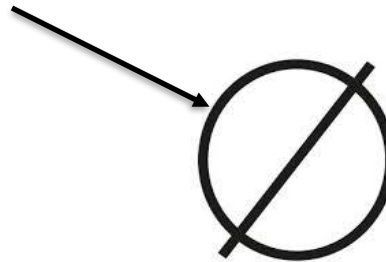
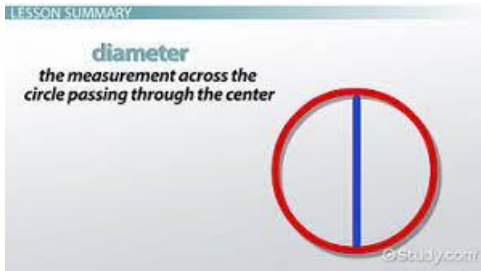

- Tolerances - Engineering **tolerance** is the permissible limit or limits of variation in: a physical dimension;; a measured value or physical property of a material, .

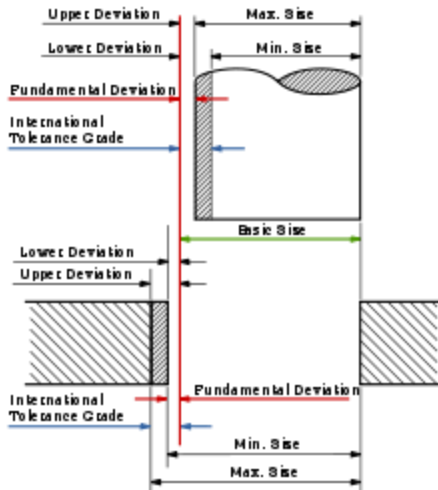

Learning Outcome 3 : Manufacturing requirements

3.1 Interpreting orthographic third angle projection drawings

Meaning of line types

- Surface finish - Surface finish, also known as surface texture or surface topography, is the nature of a surface as defined by the three characteristics of lay, surface roughness, and waviness. It comprises the small, local deviations of a surface from the perfectly flat ideal.

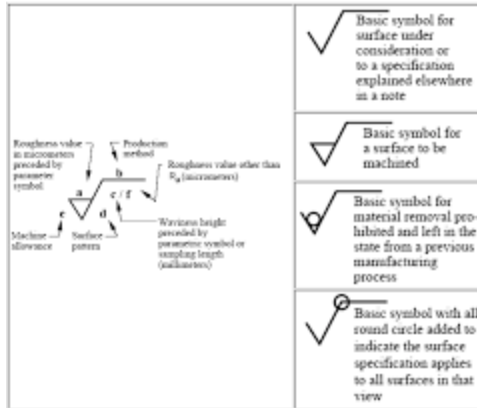

- Abbreviations

- Across flats-

AF	across flats
-----------	---------------------

- Centre line

CL or CL	centreline or centerline; class
-------------------------------------	--

- Diameter

\emptyset, DIA, and D	diameter
---	-----------------

- Drawing

DWG, dwg	drawing
-----------------	----------------

Learning Outcome 3 : Manufacturing requirements

3.1 Interpreting orthographic third angle projection drawings

Meaning of line types

- Material

Mtl

Material

- Square

Sq

Square

Learning Outcome 3 : Manufacturing requirements

3.1 Interpreting orthographic third angle projection drawings

Representation of mechanical features

- Threads - 

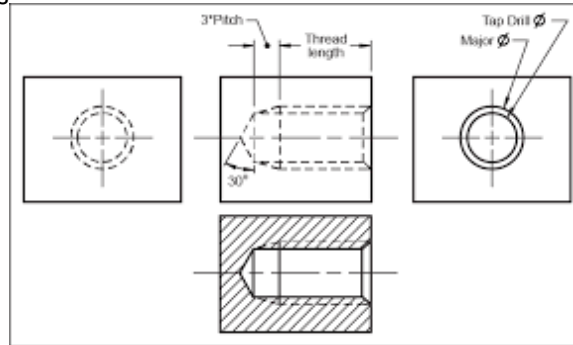

- Holes - 

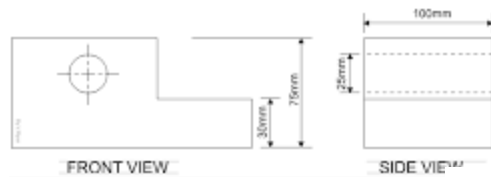

- Chamfers - 

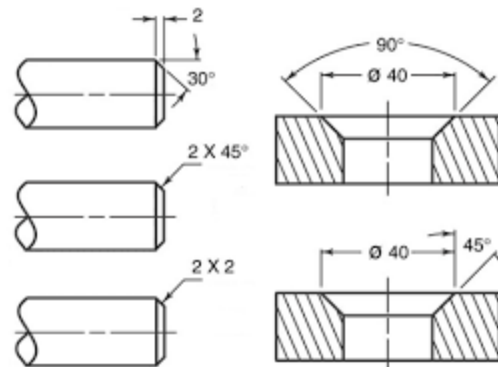

Learning Outcome 3 : Manufacturing requirements

3.1 Interpreting orthographic third angle projection drawings

Representation of mechanical features:

- Countersinks -

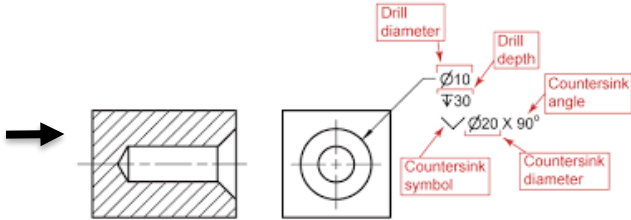

- Knurls -

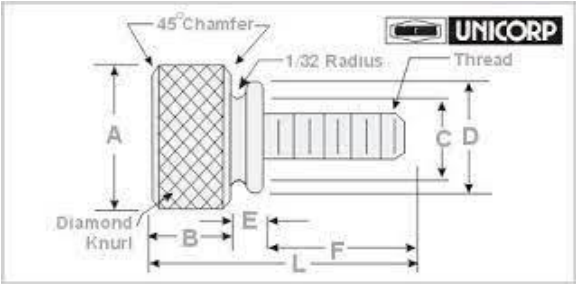

Learning Outcome 3 : Manufacturing requirements

3.2 Influence of the scale of manufacture on the production method

Scales of manufacture

- **One-off- one-off production**, involves producing custom work, such as a one-off product for a specific customer or a small batch of work in quantities usually less than those of mass-market products. This can include large scale projects, such as a bridge, ship, stadium, multi- storey building or tower, Other examples of one offs are - **specialist jewellery, made to measure clothing, bespoke furniture and many more**
- **Batch** - Batch production is **a method whereby a group of identical products are produced simultaneously (rather than one at a time)**. It is up to the manufacturer to decide how big the batch will be, and how often these batches will be made. Each batch goes through the separate stages of the manufacturing process together. **Batch Production Examples:**
 - Baked goods.
 - Clothing.
 - Computer chips.
 - Computer software.
 - Die- or mould-making.
 - Electrical goods.
 - Flat-pack furniture.
 - Jet engine production
- **Mass** - Mass production is **the manufacturing of large quantities of standardized products, often using assembly lines or automation technology**. Mass production facilitates the efficient production of a large number of similar products.
 - Examples of mass production include the following:
 - canned goods
 - over-the-counter drugs
 - household appliances

Learning Outcome 3 : Manufacturing requirements

3.2 Influence of the scale of manufacture on the production method

Advantages and limitations of jigs, fixtures, templates and moulds

Jigs - A jig is a type of custom-made tool used to control the location and/or motion of parts or other tools.
e.g. A bicycle frame building jig ..

Fixtures - A **fixture** is a work-holding or support device used in the manufacturing industry.^{[1][2]} Fixtures are used to securely locate (position in a specific location or orientation) and support the work, ensuring that all parts produced using the fixture will maintain conformity and interchangeability. Using a fixture improves the economy of production by allowing smooth operation and quick transition from part to part, reducing the requirement for skilled labor by simplifying how workpieces are mounted, and increasing conformity across a production run

A fixture differs from a jig in that when a fixture is used, the tool must move relative to the workpiece; a jig moves the piece while the tool remains stationary

Templates - What is a template in engineering? **Templates have pre-dimensional holes that are in the right scale, so engineers can accurately draw a specific symbol or sign.** Letter templates can be used to draw text (such as digits and letter characters), while others can be used to draw circles and arcs.

Moulds - Moulding is a **manufacturing process that involves shaping a liquid or malleable raw material by using a fixed frame**; known as either a mould or a matrix. The mould is generally a hollow cavity receptacle, commonly made of metal, where liquid plastic, metal, ceramic, or glass material is poured.

Learning Outcome 3 : Manufacturing requirements

3.2 Influence of the scale of manufacture on the production method

Level of automation

- Manual control – a machine operated by a human. More likely to make mistakes. Generally inexpensive. Usually less accurate but can be more versatile than a CNC machine
- CAM processes- Computer Aided Manufacturing (CAM) is **the use of software and computer-controlled machinery to automate a manufacturing process**. Based on that definition, you need three components for a CAM system to function: Software that tells a machine how to make a product by generating toolpaths
 - Examples include:
Lathes.
CNC routers.
Water cutters.
Plasma cutters.
Laser cutters.
Milling machines.
Electrical Discharge Machines (EDM)
- Fully automated robotic control- Robotics could be controlled in various ways, which includes using manual control, wireless control, semi-autonomous (which is a mix of fully automatic and wireless control), and fully autonomous (which is **when it uses artificial intelligence to move on its own**, but there could be options to make it manually controlled)

Description, Application of robots:

Articulated, Delta (or Parallel), SCARA, Polar, Cartesian and Cylindrical robots

Advantages/Disadvantages of Robotics in Engineering Manufacture

Very accurate, precise, less labour intensive, does not need breaks

Expensive to purchase and set up, training needed to operate, only good for mass production

Learning Outcome 3 : Manufacturing requirements

3.2 Influence of the scale of manufacture on the production method

Level of automation

Advantages and limitations of using CAM machines to manufacture parts

Advantages

1. CNC machines can be used continuously 24 hours a day, 365 days a year and only need to be switched off for occasional maintenance.
2. CNC machines are programmed with a design which can then be manufactured hundreds or even thousands of times. Each manufactured product will be exactly the same.
3. Less skilled/trained people can operate CNCs unlike manual lathes / milling machines etc.. which need skilled engineers.
4. CNC machines can be updated by improving the software used to drive the machines
5. Training in the use of CNCs is available through the use of 'virtual software'. This is software that allows the operator to practice using the CNC machine on the screen of a computer. The software is similar to a computer game.
6. CNC machines can be programmed by advanced design software such as Pro/DESKTOP®, enabling the manufacture of products that cannot be made by manual machines, even those used by skilled designers / engineers.
7. Modern design software allows the designer to simulate the manufacture of his/her idea. There is no need to make a prototype or a model. This saves time and money.
8. One person can supervise many CNC machines as once they are programmed they can usually be left to work by themselves. Sometimes only the cutting tools need replacing occasionally.
9. A skilled engineer can make the same component many times. However, if each component is carefully studied, each one will vary slightly. A CNC machine will manufacture each component as an exact match

Learning Outcome 3 : Manufacturing requirements

3.2 Influence of the scale of manufacture on the production method

Level of automation

Advantages and limitations of using CAM machines to manufacture parts

Limitations

1. CNC machines are more expensive than manually operated machines, although costs are slowly coming down.
2. The CNC machine operator only needs basic training and skills, enough to supervise several machines. In years gone by, engineers needed years of training to operate centre lathes, milling machines and other manually operated machines. This means many of the old skills are been lost.
3. Less workers are required to operate CNC machines compared to manually operated machines. Investment in CNC machines can lead to unemployment.
4. Many countries no longer teach pupils / students how to use manually operated lathes / milling machines etc... Pupils / students no longer develop the detailed skills required by engineers of the past. These include mathematical and engineering skills.

Learning Outcome 3 : Manufacturing requirements

3.3 Quality

Reasons for implementing a quality system in engineering -

What is meant by quality systems?

A quality system is formally described as '**the organisational structure, responsibilities, procedures, processes and resources for implementing the management of quality**'

- Early intercept of problems in production
- Reducing waste and associated costs
- Consistency of finished products
- Conformity to industry standards and regulations
- Reduce issues at customer and returns

Quality Control as a reactive approach, measuring parts

Quality control (QC) is a **procedure or set of procedures intended to ensure that a manufactured product or performed service adheres to a defined set of quality criteria or meets the requirements of the client or customer**. QC is similar to, but not identical with, quality assurance (QA).

Quality assurance as a preventative approach putting in place systems to reduce occurrence of defects

Quality assurance (QA) is **any systematic process of determining whether a product or service meets specified requirements**. QA establishes and maintains set requirements for developing or manufacturing reliable products.

Learning Outcome 4 : Developments in engineering manufacture

4.1 Inventory management

Just in time (JIT) manufacturing - What is JIT with example?

A just-in-time (JIT) inventory system is a **management strategy that has a company receive goods as close as possible to when they are actually needed**. So, if a car assembly plant needs to install airbags, it does not keep a stock of airbags on its shelves but receives them as those cars come onto the assembly line.

Material requirements planning (MRP) - Material requirements planning is a production planning, scheduling, and inventory control system used to manage manufacturing processes. Most MRP systems are software-based, but it is possible to conduct MRP by hand as well.

4.2 Lean manufacturing - Enables businesses to increase **production**, reduce costs, Improve quality, and increase profits by following five key **principles**: identify value, map the value stream, create flow, establish pull and seek perfection

Principles of Lean manufacturing include: transport, inventory, movement,

Over production, over processing, defects, skill

The seven categories of waste

- Transportation
- Inventory
- Movement
- Waiting
- Over – processing
- Over – production
- Defects

How reducing each waste improves the performance of manufacturing- less waste means more profit and less effect on the environment

Learning Outcome 4 : Developments in engineering manufacture

4.3 Globalisation

Globalization is **a term used to describe how trade and technology have made the world into a more connected and interdependent place**. Globalization also captures in its scope the economic and social changes that have come about as a result

International standards - An international standard is a technical standard developed by one or more international standards organizations. International standards are available for consideration and use worldwide. The most prominent such organization is the International Organization for Standardization.

ISO has till now has brought **about 22521** International Standards, covering almost every industry, from technology to food safety, service, to agriculture and healthcare. However, ISO 9001 and ISO 14001 are most generic ISO Standards, and they are applicable to most types of business and organizations.

Influence on employment opportunities – **how a globalisation system helps dictate opportunities for employees**

Differences in employment conditions – **how this affects production and cost**

Influence on product cost – **what factors can directly affect how much a product is manufactured and sold for**

Implications for sustainability - **What is sustainability? Sustainability means meeting our own needs without compromising the ability of future generations to meet their own needs**. In addition to natural resources, we also need social and economic resources. Sustainability is not just environmental-ism

Considerations of economic, social, ethical and environmental implications – **the impact of these factors on how materials are sourced and used, where and how products are made and the effect on communities**

Engineering Manufacturing Knowledge Organiser

Unit R015: Manufacturing a one-off product

Learning Outcome/Topic Area 1: Planning
the production of a one-off product

Learning Outcome/Topic Area 2:
Measuring and marking out

Learning Outcome/Topic Area 3: Safely
use processes, tools and equipment to
make a product

Unit R015 – Manufacturing a one-off product

Learning Outcome 1 : Planning the production of a one-off product

1.1 Interpret an engineering drawing to identify information to facilitate manufacture

Identify required form and mechanical features

- Threads-

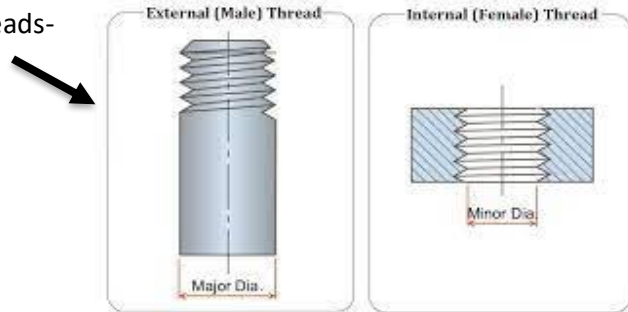

- Countersinks -

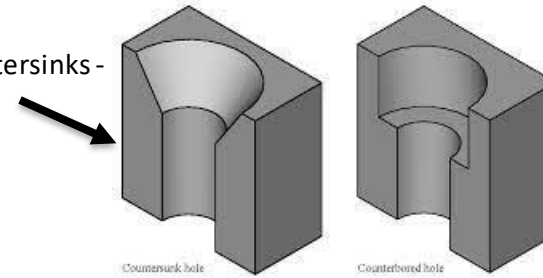

- Holes -

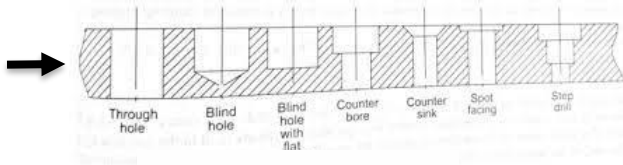

- Chamfers -

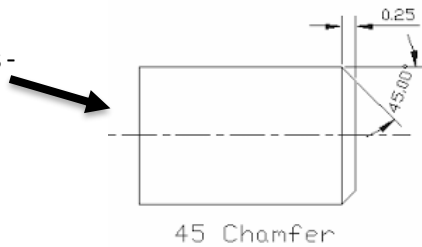

- Knurls -

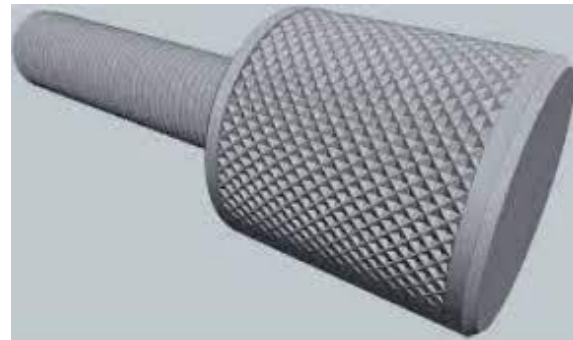

Unit R015 – Manufacturing a one-off product

Learning Outcome 1 : Planning the production of a one-off product

1.1 Interpret an engineering drawing to identify information to facilitate manufacture

Identify required dimensions and characteristics

- Linear measurements
- Radius
- Diameter
- Tolerances

See reference to these points in
Unit R014 L03

Surface finish

1.2 Prepare a production plan to manufacture a one-off product

Materials required

Processes, tools and equipment required

Sequence of operations

Health and safety considerations

Quality control requirements

**See next page for example of
a Production Plan**

Unit R015 – Manufacturing a one-off product

Learning Outcome 1 : Planning the production of a one-off product

1.2 Prepare a production plan to manufacture a one-off product

Production Plan

Production planning is the planning of production and manufacturing modules in a company or industry. It utilizes the resource allocation of activities of employees, materials and production capacity, in order to serve different customers.

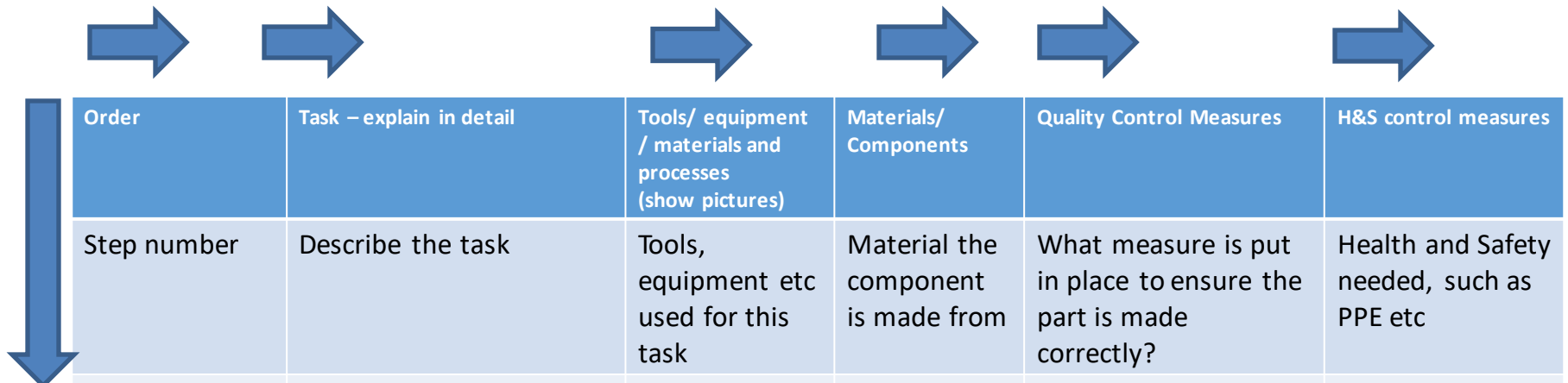

Order	Task – explain in detail	Tools/ equipment / materials and processes (show pictures)	Materials/ Components	Quality Control Measures	H&S control measures
Step number	Describe the task	Tools, equipment etc used for this task	Material the component is made from	What measure is put in place to ensure the part is made correctly?	Health and Safety needed, such as PPE etc

Unit R015 – Manufacturing a one-off product

Learning Outcome 1 : Planning the production of a one-off product

1.2 Prepare a production plan to manufacture a one-off product

Example of a Production Plan

OCR Level 1-2 Cambridge National Award/ certificate in Engineering Manufacture

Production Plan

Order	Task	Tools/ equipment/ materials and processes	Quality control measures including timing	H&S control measures
1. Checking and preparing before machining	You will need to check the stock size of the product, if the material is right and if the length and width match to the requirements. Then take the 1.5m billet and mark using a metal ruler and a marker every 60mm to produce 25 billets to machine with. Once measured, recheck to not make any mistakes and waste material. Then, clamp the acetal billet with paper around it to avoid any damage being caused to the material from the clamps of the vice. Then saw where you have made the markings until 25 billets are produced.	Acetal, calliper, hack-saw, vice, paper, marker, metal ruler.	You need to check if all qualities match to what is needed before machining because if the material is wrong and you begin to machine the component, this means that you have wasted time and money because the product wouldn't match the requirements.	<ul style="list-style-type: none"> ➤ Have your hair tied up to stop your hair from being in your way and being trapped ➤ No jewellery
2. Beginning to machine - length and width	Clamp the acetal in the 3-jaw chuck and tighten with a chuck key making sure that the billet is sticking out by 50mm. Then you need to turn down the diameter of the acetal to 15mm and cut it to the length of 40mm. Begin by lining up the tool with the acetal using the saddle and handle and the cross slide. Then set the dial on the saddle handle to 0 without moving the tool itself. Now put your goggles on and start the machine (by pressing the green button). Twist the cross slide to 1mm and turn the saddle lathe to 40mm by looking at the dial. You are going to turn down the diameter by 1mm each time until you reached the desired diameter which is 15mm. Every time you cut off 1mm, you stop the machine by pressing the red button. Then using the caliper, check how much more you need to cut off. Then, when you get closer to 15mm be careful to not cut off too much than needed- make the number as close as possible.	Acetal, manual lathe, digital vernier calliper, goggles, chuck key	Make sure you so that the billet doesn't fall out when the machine is on and take care when cutting down the diameter so that you don't come out of the tolerance of 0.2mm.	<ul style="list-style-type: none"> ➤ When using the machine make sure that if you've got long hair, you've got it tied up so that it doesn't get caught into the machine.
3. Making the shoulder/ main section	Clamp the acetal into the 3-jaw chuck and tighten with a chuck key. Once completed, check if it is secure by turning the 3-jaw chuck. Using the saddle handle and cross slide, line up the tool with the end of the acetal and set the saddle handle and the cross slide to 0 without moving the tool from place. Put on the goggles, place the guard down to prevent injury and turn on the centre lathe by pressing the green button. Now, you need to cut the shoulder to 12mm in diameter and 15mm in length. Firstly, set the cross slide to 0.5mm and turn the saddle handle to 15mm. Then turn off the machine using the red button and wind back out when the 3-jaw chuck stops rotating. This is done to prevent from any lines appearing on the shoulder. Pull the guard up and begin to measure the diameter using the calliper to check how much you need to cut off. Put the guard down again. Turn the cross slide to 1mm or 1.5mm and start the machine again. Turn the saddle handle to 15mm again then turn off the machine. Wind out and check the diameter again and calculate how much more you need to cut off. Make sure you don't cut off more than needed and make the diameter as close as possible to 12mm. Don't cut off more than 1mm at a time for the diameter.	Acetal, manual lathe, goggles, chuck key, digital vernier calliper	Measure as often as possible to prevent any errors. E.g. cutting off more than needed. If there is a mistake, then you are wasting time to start the component again and it is a waste of material.	<ul style="list-style-type: none"> Wear goggles at all times when you are using the machine to prevent injuries (especially from the swarf that is cut off the stick of acetal).



Unit R015 – Manufacturing a one-off product

1.3 Carry out a risk assessment

- Identify hazards (potential sources of harm)
- Identify risks (the probability of the hazard occurring)
- Identify control measures

Examples of Risk Assessments

PHOTOGRAPHY SHOOT RISK ASSESSMENT Salford Quays – Risk Assessment

HAZARD	IN WHICH LOCATION IS THIS HAZARD PRESENT?	PERSON WHO MAY BE HARMED	PROPERTY THAT COULD BE DAMAGED	RISK CONTROLS ALREADY IN PLACE	RISK ASSESSMENT *See chart	FURTHER ACTION TO BE TAKEN
I could drop the camera	Any Where you take the camera	Me	The camera	A strap on the camera for around your neck.	high	Be more careful when using this equipment
I could fall in the water	Around the water in Salford quays	Me and others	The camera and any other electronic equipment on me at the time.	Barriers to stop you	Moderate	Don't stand too close to the edge
I Could get heavy rain and get flooded out	Most likely around the water in Salford Quays	Me and others	The camera and any other electronic equipment on me at the time.	The water shouldn't be able to flood	low	Check the weather before you go out and while you are out
I could fall down some stairs	Around any stairs, or in any buildings	Me	The camera	There's a hand rail	High	Make sure you take our time, don't rush and use the handrail
I Could scratch the lenses in your bag	At any point if you have the camera out with you.	Me	The camera	You could use a lenses cover	High	Use the camera bag, and make sure there's no clutter in there.
My Bottle leaks over camera	From leaving your house to arriving home.	Me	The camera	Use a camera bag	High	Make sure you use a good, unlikable bottle.
Could get hit by a car	In and Round Salford quays	Me and the driver	Me, the car, and other equipment	A sidewalk and a road	High	Wearing something making yourself visible
There could be a fire in a building	Salford Quays	Me and others	Me, the building, and a lot of equipment	There are sprinklers placed in and around the building	Moderate	Make sure you don't set fires near a building.

Unit R015 – Manufacturing a one-off product

Examples of Risk Assessments

	Hazard	Control Measures	Who might be affected?	Level of Risk
<p>The hazards in completing practical work in a D&T workshop when social distancing.</p> <p>Transmitting the virus from person to person.</p>	Number of Students in a workshop (safely social distancing)	Students to a bench facing the front (writing tasks). This is achievable in Rooms 52 and 58. In other rooms screens will be used on benches where students face each other but are 1m apart. Maximum number of students in workshops safely is 21. Seating plans should be written and used and visible within each classroom.	Students, Staff and Technicians	Low
	Using Hand and Power Tools	Hand tools should be grouped into project boxes as per year group 'bubbles' for use in practical lessons. Positioned to limit movement around the workshop. All machine tools to be sanitized in between Year group classes	Students, Staff and Technicians	Low/managed
	Using Machines	Hand sanitizer next to each piece of equipment. Students to use before and after use.	Students, Staff and Technicians	Low
	Teacher keeping social distancing	Teacher/Technician to stay 2m apart from students when possible. Teacher to use visor when having to be within 1m of students for more than 5 minutes.	Students, Staff and Technicians	Low
	Teacher demonstrations	Plan to minimise students crowding around a bench. Film demonstrations before hand and play to students.	Students, Staff and Technicians	Low
	Student/staff movement around the workshop	Temporarily rehome tools to minimise student movement around the workshop.	Students, Staff and Technicians	Low
	Multiple Practical lessons in a workshop during a day	Plan in Workshop downtime between classes to give time for sanitizing. Rotate tools between classes so tools have time to be sanitised. Use dedicated tools box for project use within that year 'bubble'. Tools limited so additional units will be needed	Staff and Technicians	Low
	Stock and Contamination of PPE e.g. Goggles and aprons	Goggles will need to be routinely sterilized in Milton solution. Students to either wear disposable aprons or not wear an apron.	Staff and Technicians	Low

Unit R015 – Manufacturing a one-off product

Learning Outcome 2 : Measuring and marking out

2.1 Select and safely use equipment for marking out

2.1.1 Equipment

Rules-



Dividers



Scribers



Scribing blocks



Unit R015 – Manufacturing a one-off product

Learning Outcome 2 : Measuring and marking out

2.1 Select and safely use equipment for marking out

2.1.1 Equipment

Surface plates -



Punches



Squares -

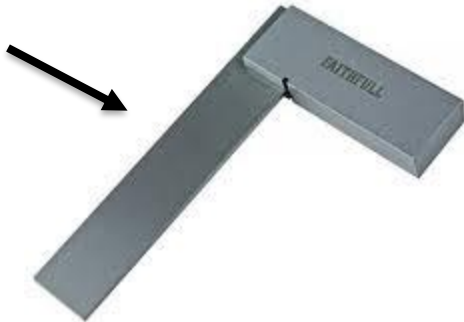

Protractors



Unit R015 – Manufacturing a one-off product

Learning Outcome 2 : Measuring and marking out

2.1 Select and safely use equipment for marking out

2.1.1 Equipment

Angle plates -



Unit R015 – Manufacturing a one-off product

Learning Outcome 2 : Measuring and marking out

2.1.2 Marking out techniques

Datum - A **datum reference** or just **datum** (plural: **datums**^[Note 1]) is some important part of an object—such as a point, line, plane, hole, set of holes, or pair of surfaces—that serves as a reference in defining the geometry of the object and (often) in measuring aspects of the actual geometry to assess how closely they match with the nominal value, which may be an ideal, standard, average, or desired value. For example, on a car's wheel, the lug nut holes define a bolt circle that is a datum from which the location of the rim can be defined and measured. This matters because the hub and rim need to be concentric to within close limits (or else the wheel will not roll smoothly). The concept of datums is used in many fields, including carpentry, metalworking, needlework, geometric dimensioning and tolerancing (GD&T), aviation, surveying, and other

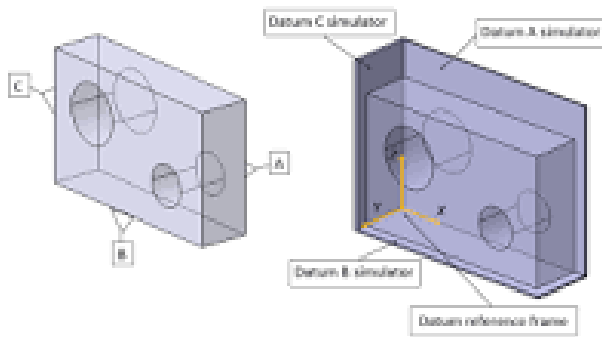

Centre lines - What are Centerlines? Centerlines are one of the most frequently used tools in engineering drawing. Their basic purpose is **to show circular/cylindrical features in a drawing, which are found in abundance in mechanical parts**. Common examples of such features include bolt holes, pins, discs, etc.

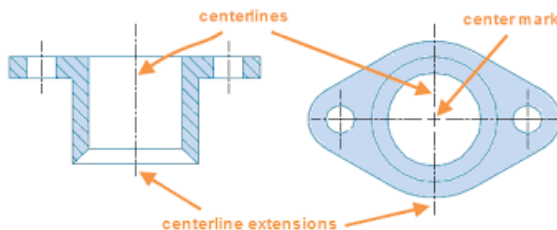

Unit R015 – Manufacturing a one-off product

Learning Outcome 2 : Measuring and marking out

2.1.2 Marking out techniques

Profiles -

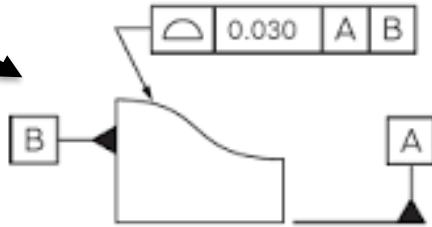

• Square/rectangular -

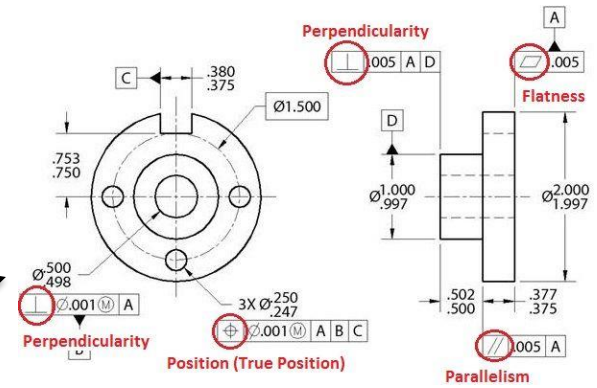

• Angular-

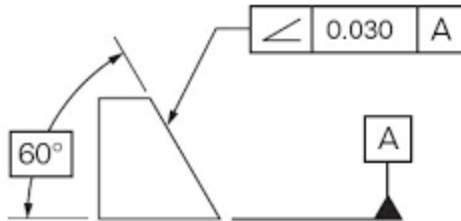

• Radial

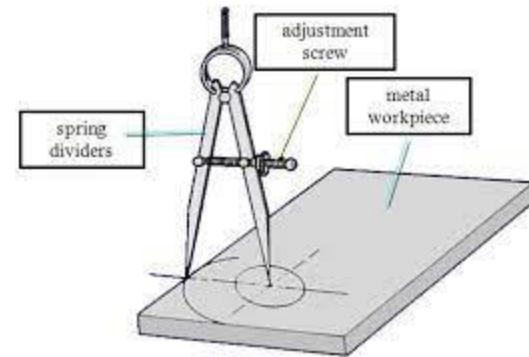

Unit R015 – Manufacturing a one-off product

Learning Outcome 2 : Measuring and marking out

2.1.2 Marking out techniques

Circles -

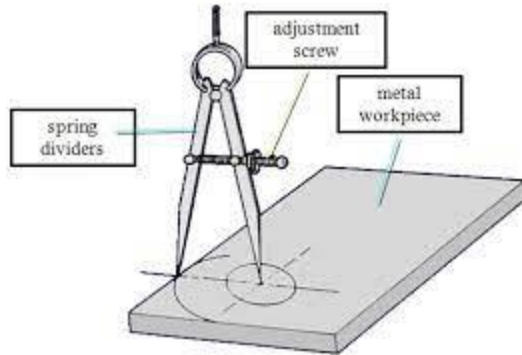

Hole positions -

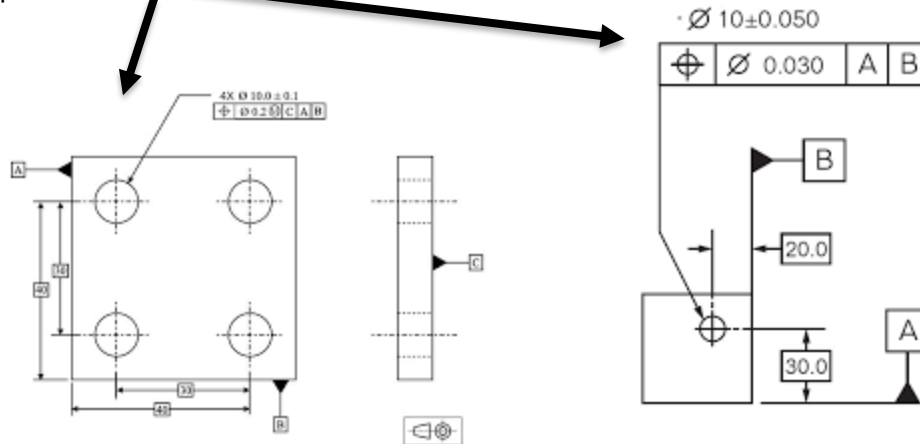

Learning Outcome 2 : Measuring and marking out

2.2 Select and use measuring equipment

Rules



Digital Vernier callipers

- External
- Internal
- Depth

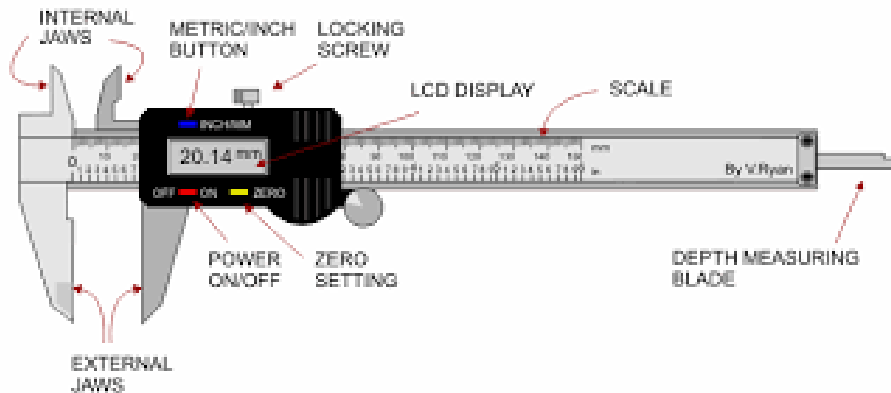

Learning Outcome 2 : Measuring and marking out

2.2 Select and use measuring equipment

Micrometers

- External

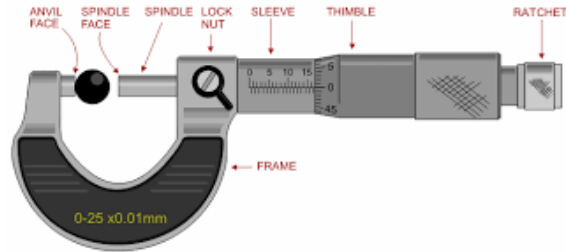

Internal



- Depth

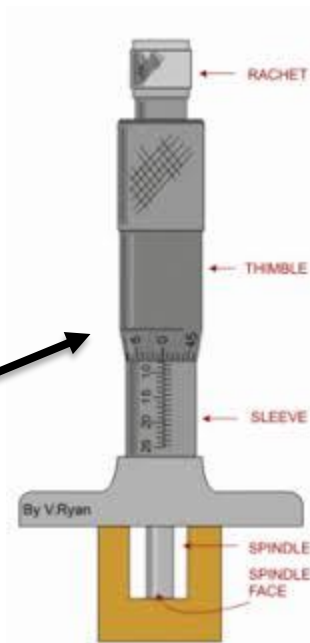

Learning Outcome 2 : Measuring and marking out

2.2 Select and use measuring equipment

Height gauge -



Dial Test Indicator (DTI)



Learning Outcome 3 : Safely use processes, tools and equipment to make a product

3.1 Manually controlled machining operations

Drilling - Drilling is a cutting process that uses a drill bit to cut a hole of circular cross-section in solid materials. The drill bit is usually a rotary cutting tool, often multi-point. The bit is pressed against the work-piece and rotated at rates from hundreds to thousands of revolutions per minute.

Turning using a centre lathe - Turning is a machining process in which a cutting tool, typically a non-rotary tool bit, describes a helix toolpath by moving more or less linearly while the workpiece rotates.

Milling - Milling is the process of machining using rotary cutters to remove material by advancing a cutter into a workpiece. This may be done varying direction on one or several axes, cutter head speed, and pressure

3.2 Tools and equipment

Saws

- Hacksaw - A hacksaw is a fine-toothed saw, originally and mainly made for cutting metal.
- Junior hacksaw – smaller version of a hacksaw, also for cutting metal



Learning Outcome 3 : Safely use processes, tools and equipment to make a product

3.2 Tools and equipment

Guillotine- for cutting sheet metal

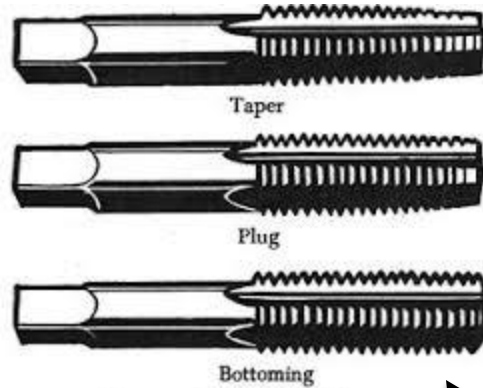
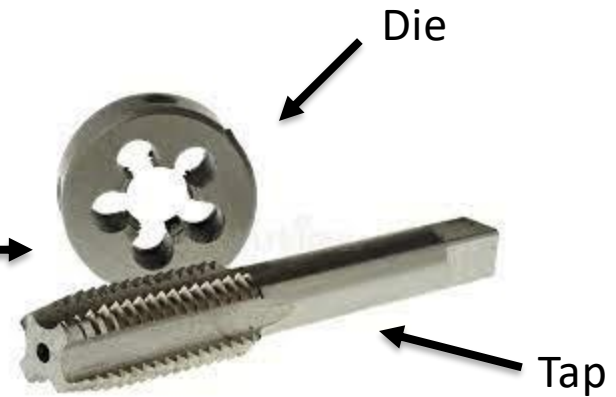

FIGURE 12-27. Hand taps.

Tap and die - A tap is a threaded tool that cuts or forms threads in the female portion of a mating pair. Therefore, a tap will create threads in the inside of a hole. On the other hand, a die is a threaded tool that cuts or forms threads in the male portion of a mating pair.



Files



Die

Tap

Learning Outcome 3 : Safely use processes, tools and equipment to make a product

3.2 Tools and equipment

Press (sheet bending) - **What is press bending?**

Bending is a **manufacturing process where sheet metals are plastically deformed into complex parts by the application of a bending moment**. The plate is pressed to the designed angle and bending radius by flanging a sheet metal part between a punch and die, selected for the individual part geometry

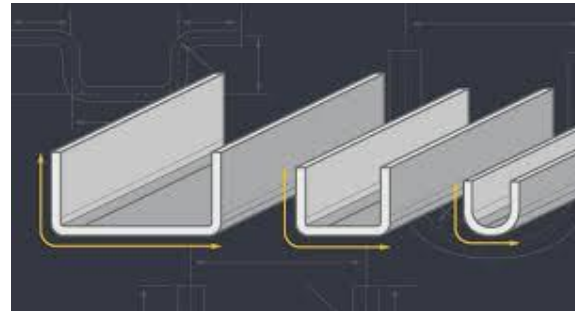
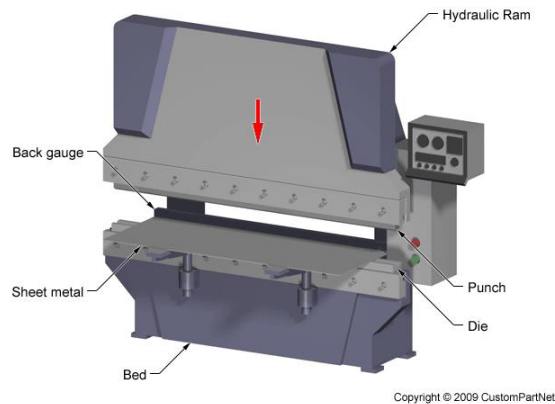

Learning Outcome 3 : Safely use processes, tools and equipment to make a product

3.3 Joining techniques

Brazing- What is the process of brazing?

brazing, **process for joining two pieces of metal that involves the application of heat and the addition of a filler metal**. This filler metal, which has a lower melting point than the metals to be joined, is either pre-placed or fed into the joint as the parts are heated

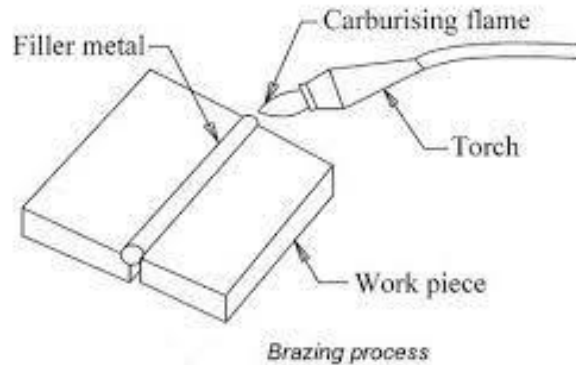

Pop-rivets- What is a pop riveted joint?

Pop riveting is a **technique that is used to join thin pieces of metal and it can also be used to join plastic sheet**. The rivet has two parts; the pin and the rivet

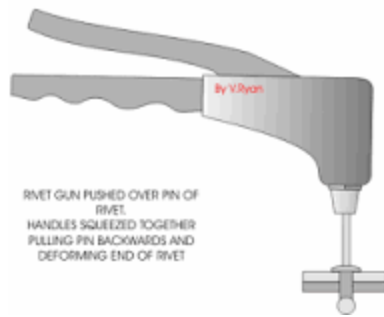

Learning Outcome 3 : Safely use processes, tools and equipment to make a product

3.3 Joining techniques

Mechanical fastenings

- Nuts and bolts -

 Hexagon Head Bolt	 Square Head Bolt	 Hexagon Head Set Screw	 Countersunk Head Bolt	 Hexagon Socket Head Cap Screw	 Cap Head Square Neck Bolt (Carriage Bolt)
 Stud Bolt	 Continuous Thread Stud (All Thread Rod)	 Eye Bolt	 Eye Bolt	 Wing Bolt	 Knob Bolt
 Hexagon Nut	 Hexagon Slotted Nut	 Hexagon Castellated Nut	 Square Nut	 Plate Nut	 Pipe Nut
 Long Nut	 Hexagon Cap Nut	 Wing Nut	 Square Weld Nut	 Hexagon Weld Nut	 Hexagon Flange Nut
 Eye Nut	 Square Set Screw	 Slotted Set Screw	 Hexagon Socket Set Screw	 Hexagon Socket Headless Tapered Pipe Plug	 Thumb Screw
 Helisert	 Slotted Round Head Machine Screw	 Slotted Countersunk Machine Screw	 Slotted Flat Fillister Head Machine Screw	 Cross Recessed Pan Head Machine Screw	 Cross Recessed Countersunk Head Machine Screw

Learning Outcome 3 : Safely use processes, tools and equipment to make a product

3.3 Joining techniques

Mechanical fastenings

- Self – tapping screws - *What is a self-tapping screw used for?*
- As the name suggests, self-tapping screws are screws that have the ability to tap threads into the material. Self-tapping screws are used for **all sorts of material including wood, metal, and brick**. These screws cannot drill through metal and require a pilot hole to be pre-drilled before installation.



Engineering Manufacturing Knowledge Organiser

and equipment to make products in quantity

Unit R016: Manufacturing in quantity

Learning Outcome/Topic Area 1:

Preparing for manufacture

Learning Outcome/Topic Area 2:

Develop programmes to operate CNC equipment

Learning Outcome/Topic

Area 3: Safely use processes

Unit R016 – Manufacturing in quantity

Learning Outcome 1 : Preparing for manufacture

1.1 Manufacture and use production aids

Manufacture and use:

- Go-No Go gauges - A go/no-go gauge refers to an inspection tool used to check a workpiece against its allowed tolerances via a go/no-go test. Its name is derived from two tests: the check involves the workpiece having to pass one test and fail the other.



1.2 Sequence of operations

Determine the sequence of operations required for a manufactured part. The order in which it will be manufactured.

1.3 Operating parameters

Determine appropriate operating parameters for Computer Numerical Control (CNC) equipment

Unit R016 – Manufacturing in quantity

Learning Outcome 1 : Preparing for manufacture

1.4 Standard operating procedures (SOPs)

Produce Standard Operating Procedures (SOPs) for the use of manufacturing processes- A standard operating procedure (SOP) is a **set of step-by-step instructions compiled by an organization to help workers carry out routine operations**. SOPs aim to achieve efficiency, quality output and uniformity of performance, while reducing miscommunication and failure to comply with industry regulations.

Standard Operating Procedure (SOP)



SOP Name	
Edit this text with the SOP name for this process	

1. Purpose	<ul style="list-style-type: none">Edit this text with the description of the purpose for this process..
2. Scope	<ul style="list-style-type: none">Edit this text to list the scope for this process..
3. Deliverables	<ul style="list-style-type: none">Edit this text to list deliverables for this process..
4. Responsibilities	<ul style="list-style-type: none">Edit this text to describe who is responsible for what..
5. Definitions	<ul style="list-style-type: none">Edit this text to include key definitions for this process..
6. Materials	<ul style="list-style-type: none">Edit this text with a list of resources or materials required to make this process work..

7. Process Diagram

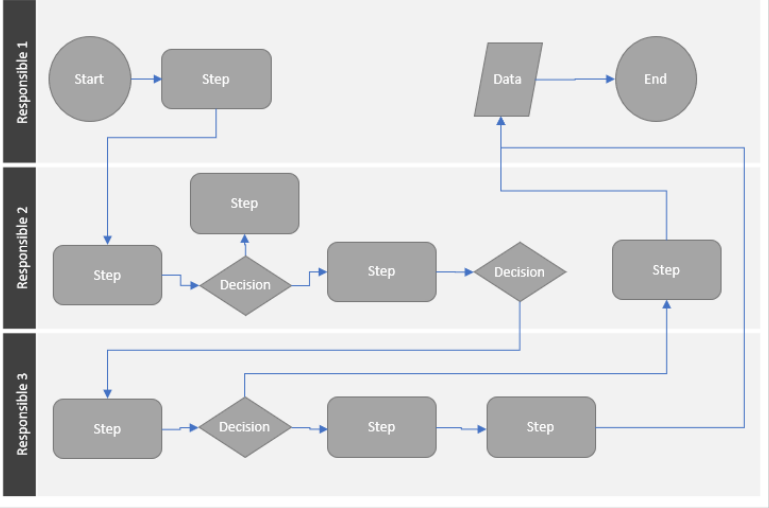

2

Want more best practices? Visit [Praxie.com](https://www.praxie.com)

Learning Outcome 2 : Develop programmes to operate CNC equipment

2.1 Use Computer Aided Design (CAD) software

Use provided CAD drawings to create working drawings suitable for the CNC manufacture of parts

Example of a CAD drawing:



Example of an Engineering drawing of the same component

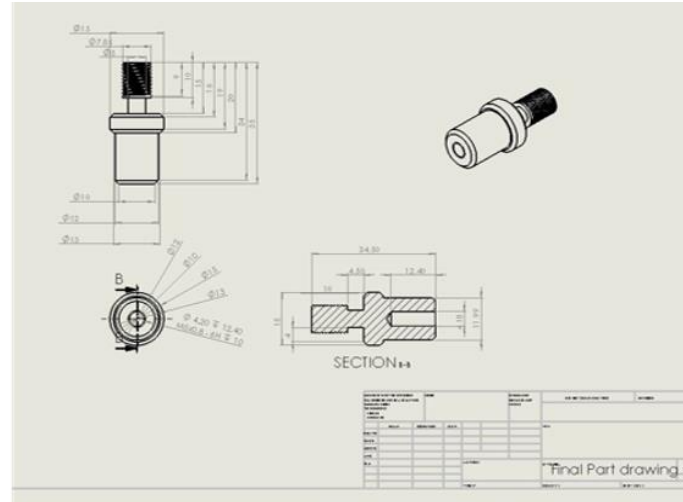

Carry out on-screen simulation of CNC process - CNC simulation tools are **mathematical applications designed to predict the behavior, performance, and outcome of certain manufacturing processes**. They provide the means for testing and verifying the CNC program, usually written in G-code, before the instructions are sent to the machine.



Examples of CNC simulation for the above component



Learning Outcome 2 : Develop programmes to operate CNC equipment

2.2 Programme CNC machining operations

Setting datum points

Use of co-ordinates

Sequence of operations

Tool change-over

Setting tool offsets

Export information from CAD software to CNC machines

Learning Outcome 3 : Safely use processes and equipment to make products in quantity

3.1 Setting up of CNC equipment

Tooling

Work holding

Setting datum points

Safety procedures

3.2 Operating CNC equipment

Operate CNC equipment safely –wearing PPE, following instructions,

3.3 Apply quality control methods for volume manufacture

Use Go-No Go gauges

Comparison of dimensional characteristics against engineering drawings

Use of statistical process control – **Statistical process control (SPC) is a method of quality control which employs statistical methods to monitor and control a process.** This helps to ensure that the process operates efficiently, producing more specification-conforming products with less waste (rework or scrap).

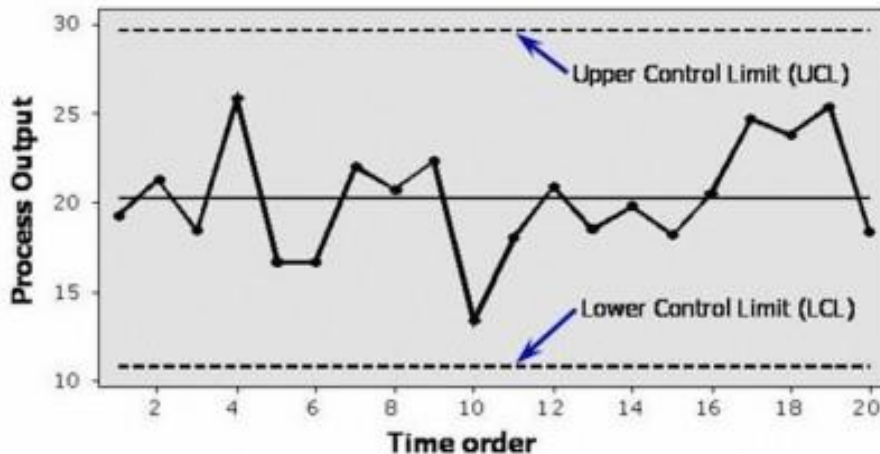

Additional Useful information

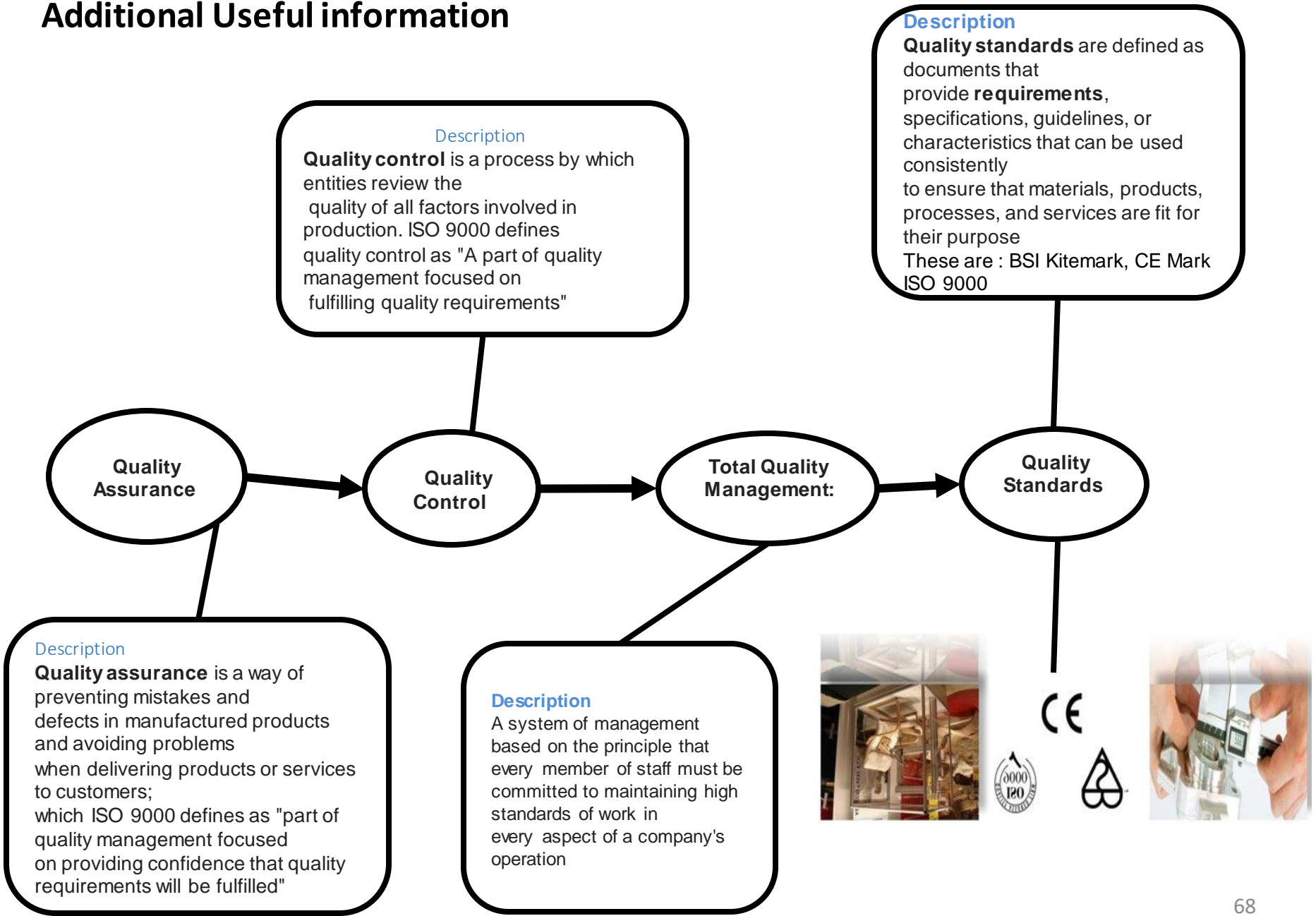

Additional Useful information

What are Modern Technologies?

CNC machinery

Smart products

Artificial intelligence

3D scanners

Lasers

Touchscreens

CAD packages

Broadband...there are loads more examples.

Advantages of modern technology

Greatly Increased production: Increased output and reduced production times meaning it can get to market quicker. They do the job within the minimal time but with maximum accuracy and efficiency.

Reduced human effort/welfare; Modern technologies can do dangerous jobs or heavy lifting, meaning humans don't have to – improving welfare/ working conditions would improve.

Reduced cost of the actual production once machinery has been purchased.

Precision & consistency – Products are more accurate and are all the same compared to human production techniques (incur errors) - consistency – zero defects, Right First Time.

<https://www.lockheedmartin.com/en-us/news/features/history/zero-defects.html>

Quality – products can be constantly monitored throughout the production process to spot problems early on (use of lasers and 3D scanners to check quality of products)

Enhanced communication -. Skype, Whatsapp, Facebook Messenger are all the examples of modern technology communication service providers.

Additional Useful information

Centre Lathe diagram

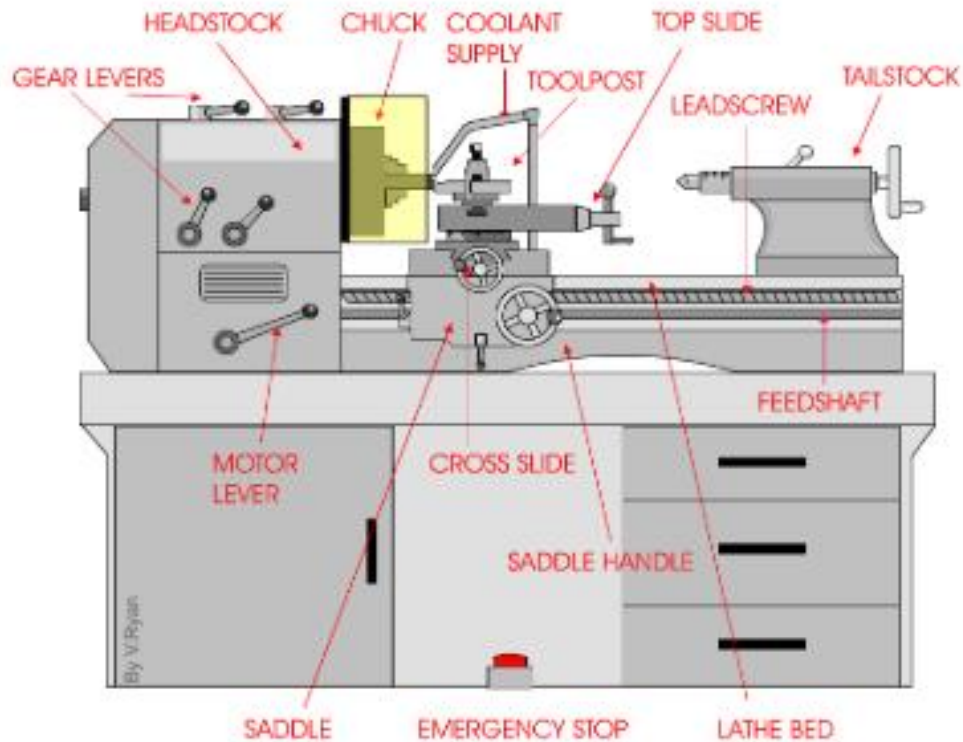

Additional Useful information

Keywords		
Heat Treatment		
Hardening	→	Heating metals to make them get harder
Tempering	→	Heating and cooling metals to make them less brittle
Annealing	→	Heating and cooling metal to make it tougher
Normalising	→	Heating of a metal and cooling at room temperature
Nitriding	→	Case hardening a metal by diffusing nitrogen into the surface
Surface Finishes		
Electroplating	→	Process of coating a metal with a layer of another metal using electricity
Galvanising	→	To cover a metal with zinc
Painting	→	To cover a metal/material with paint to protect it
Plastic/Powder Coating	→	Applying powdered plastic to heated metal to give it a protective coating
Linishing	→	To polish or remove access material using an abrasive belt
Polishing	→	To make a surface smooth and shiny

Additional Useful information

Keywords	
Destructive Testing	Test carried out to understand a specimen or material's performance by testing until failure
Crash Testing	A form of destructive testing used to ensure safe design standards, usually in motor vehicles
Non-Destructive Testing	A wide group of analysis techniques used in science and technology to evaluate the properties of material, component or system without causing damage
Coordinate Measuring Measuring (CMM)	A device that measure the geometry of physical objects by sensing points with a probe
Computer Integrated Manufacturing / Computer Integrated Engineering	The manufacturing approach of using computers to control entire production processes.
Automatic Test Equipment (ATE)	A device that performs test on a product using automation to quickly perform measurements and evaluate test results

Materials Testing Processes







Non-Destructive Testing (NDT)

Crack Testing, Conductivity Testing

Destructive Testing-

Tensile Testing, Crash Testing

Additional Useful information

Keywords	
Lean manufacturing 	Enables businesses to increase production , reduce costs, Improve quality, and increase profits by following five key principles : identify value, map the value stream, create flow, establish pull and seek perfection Principles of Lean manufacturing include: transport, inventory, movement, Over production, over processing, defects, skill
Waste Reduction 	Design for Assembly How products can be assembled in a way that reduces waste Design for Manufacture Create designs that use less material and create less waste product
Sustainable Design 	The philosophy of designing physical objects, the built environment and services to comply with the principles of economic, ecological and social sustainability
Principles of Sustainable Design/Design Considerations for Designers 	Low-impact materials Energy Efficiency Emotionally Durable Design Design for reuse and recycling Biomimicry Renewability Form
The 6R's of Sustainability 	Help designers create a product that considers it's environmental impact during the design of it. The 6R;s are : Reduce, Recycle, Refuse, Reuse, Rethink and Repair
Life Cycle Analysis 	A method used to evaluate the environmental impact of a product through its life cycle, encompassing: extraction and processing of raw materials, manufacturing, distribution, use, recycling and final disposal
Waste Prevention 	The preventing of unnecessary production of waste material